

CONCERTO
in G minor, RV 531
for Two Cellos and Piano

IL MAGNIFICO

Harriot HD.I in Italian service



1/48

LIMITED EDITION

11139-NAVI

ATTENTION



UPOZORNĚNÍ



ACHTUNG



ATTENTION



注意



Carefully read instruction sheet before assembling. When you use glue or paint, do not use near open flame and use in well ventilated room. Keep out of reach of small children. Children must not be allowed to suck any part, or pull vinyl bag over the head.



Před započatím stavby si pečlivě prostudujte stavební návod. Při používání barev a lepidel pracujte v dobře větrané místnosti. Lepidla ani barvy nepoužívejte v blízkosti otevřeného ohně. Model není určen malým dětem, mohlo by dojít k požití drobných dílů.

INSTRUCTION SIGNS * INSTR. SYMBOLS * INSTRUKTION SINNBILDEN * SYMBOLES * 記号の説明

OPTIONAL
VOLBABEND
OHNOUTSAND
BROUSITOPEN HOLE
VYVRTAT OTVORSYMETRICAL ASSEMBLY
SYMETRICKÁ MONTÁŽREMOVE
ODŘÍZNOUTREVERSE SIDE
OTOČITAPPLY EDUARD MASK
AND PAINT
POUŽÍT EDUARD MASK
NABARVIT

PARTS



DÍLY



TEILE



PIÈCES



部品

PLASTIC PARTS

A>

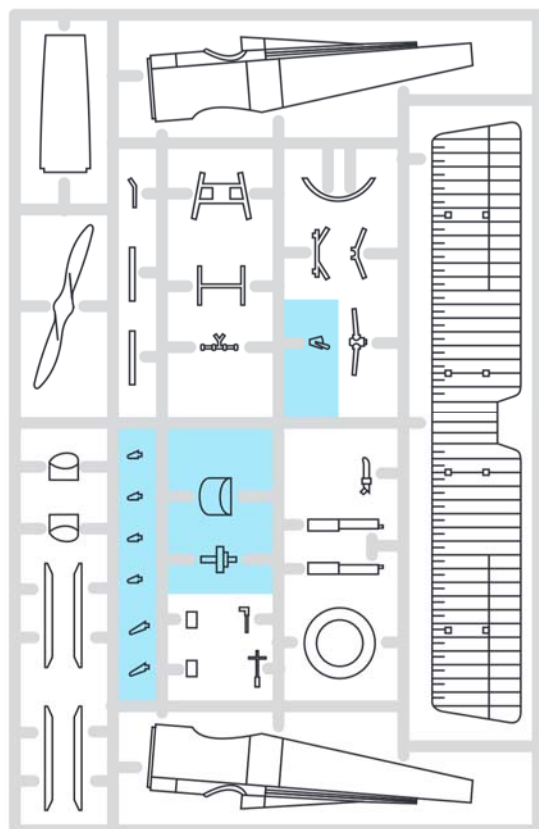

B>



B>

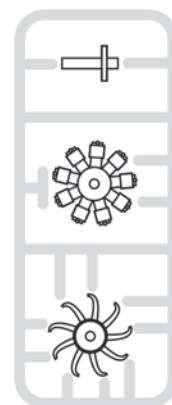

CP - CLEAR PARTS

1

PE - PHOTO ETCHED DETAIL PARTS

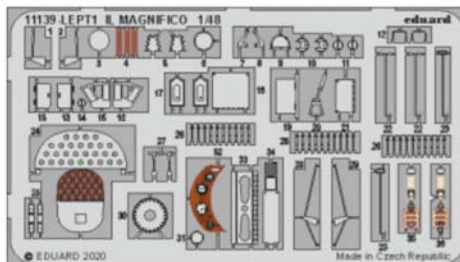

-Parts not for use. -Teile werden nicht verwendet. -Pièces à ne pas utiliser. -Tyto díly nepoužívejte při stavbě. - 使用しない部品

COLOURS



BARVY



FARBEN



PEINTURE



色

GSI Creos (GUNZE)		MISSION MODELS	
AQUEOUS	Mr.COLOR	PAINTS	
H3	C3	MMP-003	RED
H6	C6	MMP-004	GREEN
H8	C8		SILVER
H11	C62	MMP-001	FLAT WHITE
H12	C33	MMP-047	FLAT BLACK
H37	C43		WOOD BROWN
H47	C41	MMP-012	RED BROWN
H51	C11	MMP-063	LIGHT GULL GRAY
H53	C13		NEUTRAL GRAY
H81	C55	MMP-023	KHAKI

GSI Creos (GUNZE)		MISSION MODELS	
AQUEOUS	Mr.COLOR	PAINTS	
H85	C45		SAIL COLOR
H302	C302		GREEN
H430	C361	MMP-077	DARK GREEN
Mr.METAL COLOR		METALLICS	
MC2-3		MMM-006	STAINLESS
MC2-4		MMM-001	DARK IRON
MC2-8		MMM-003	ALUMINIUM
MC2-6		MMM-009	BRASS
Mr.COLOR SUPER METALLIC		METALLICS	
SM201		MMC-001	SUPER FINE SILVER

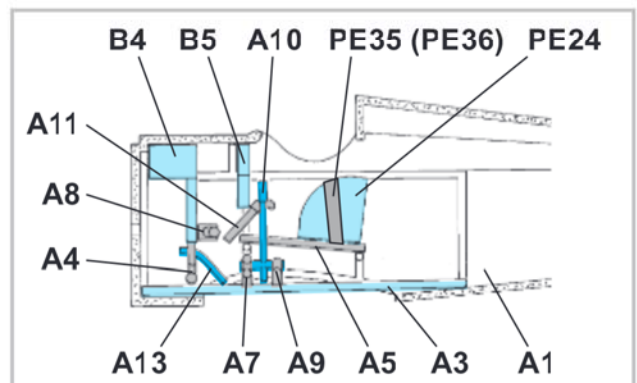
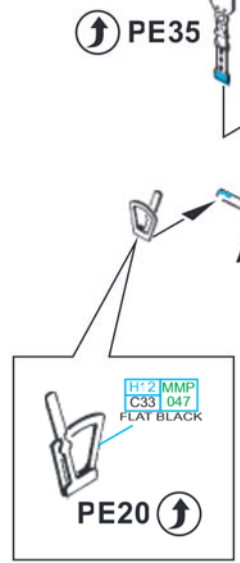
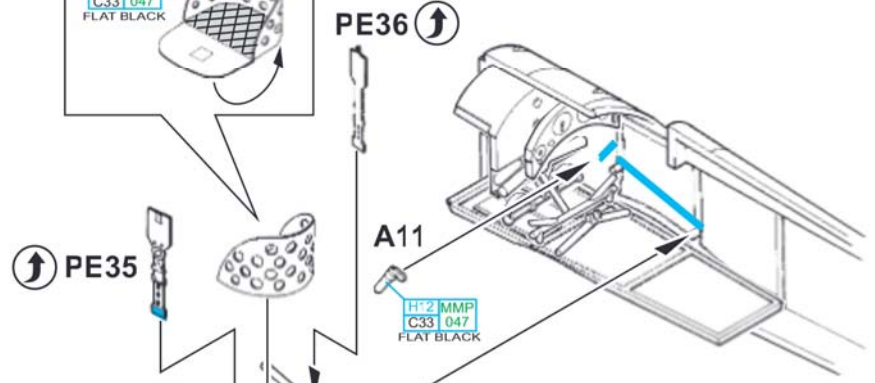
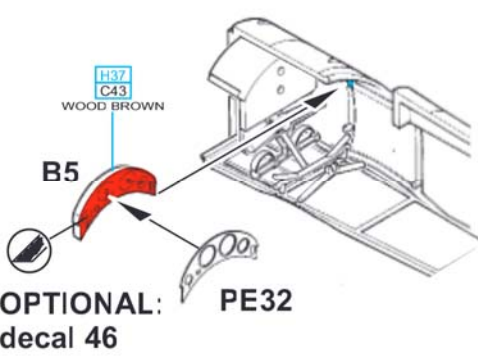
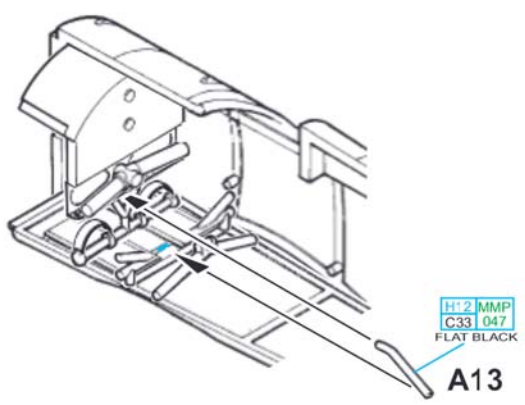
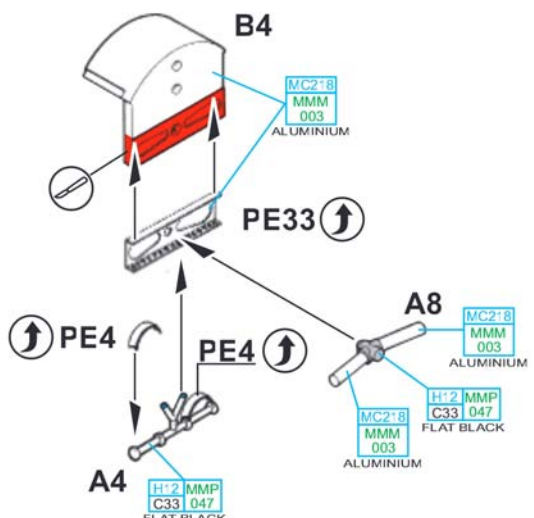
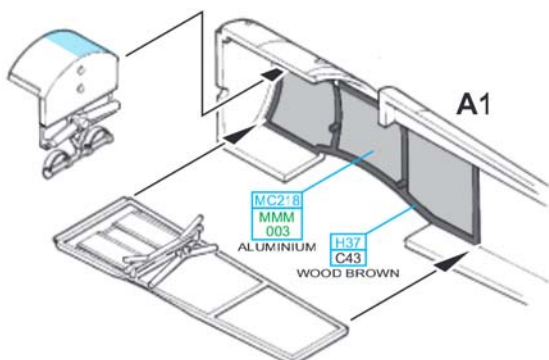
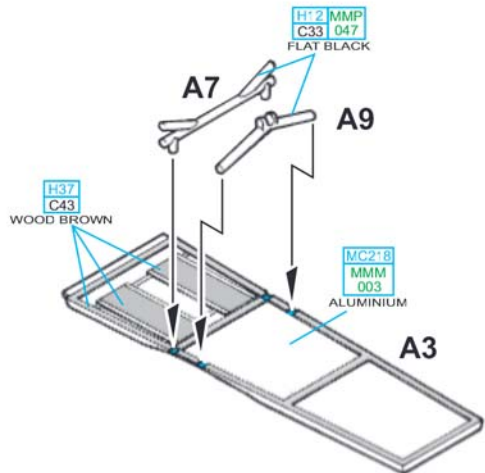

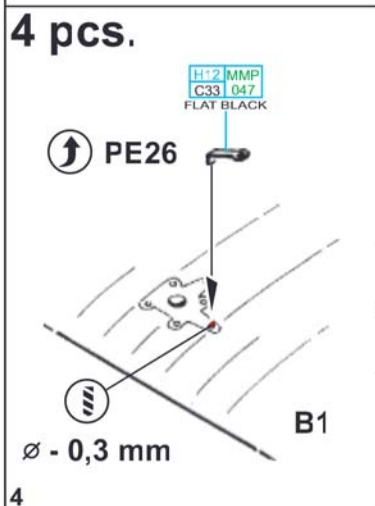
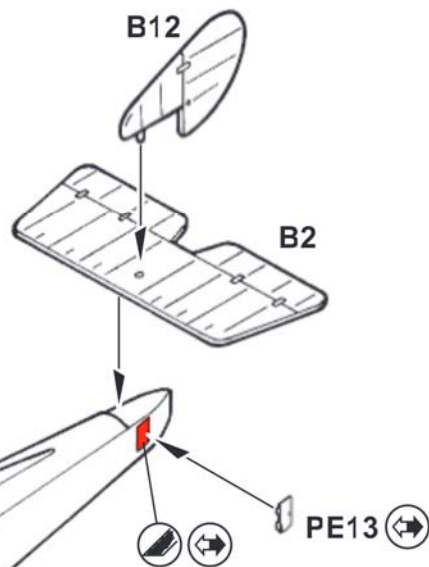
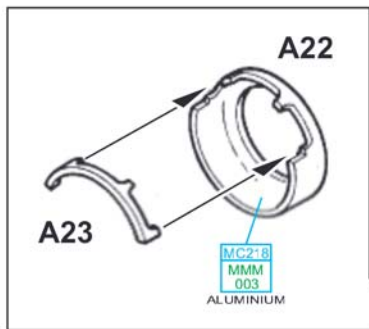
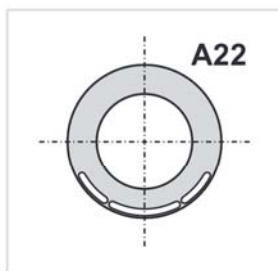
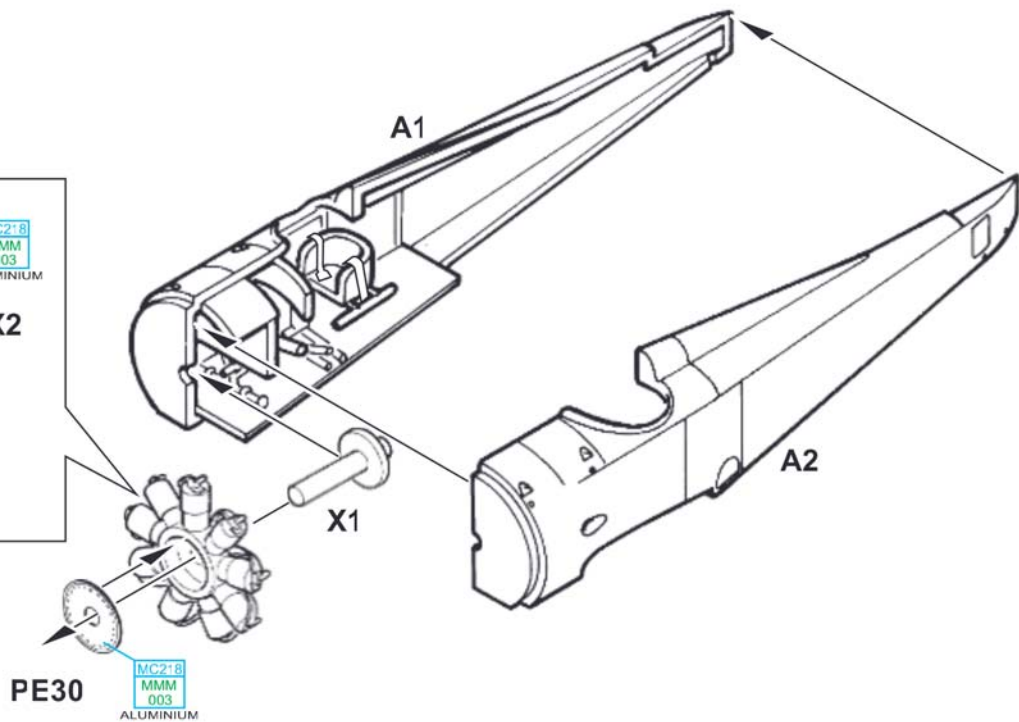
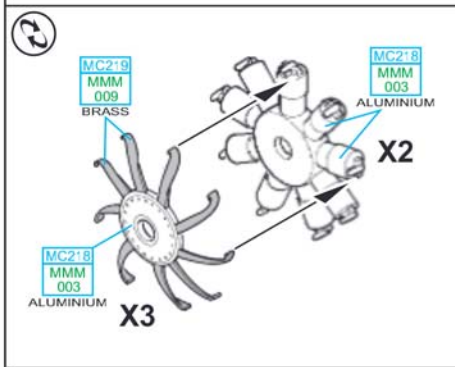

MARKINGS A C

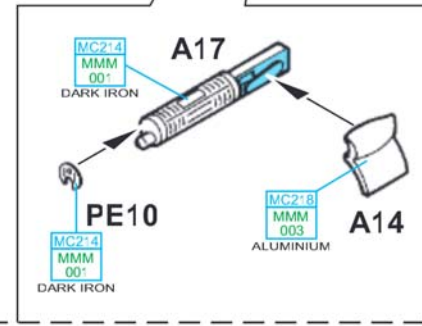
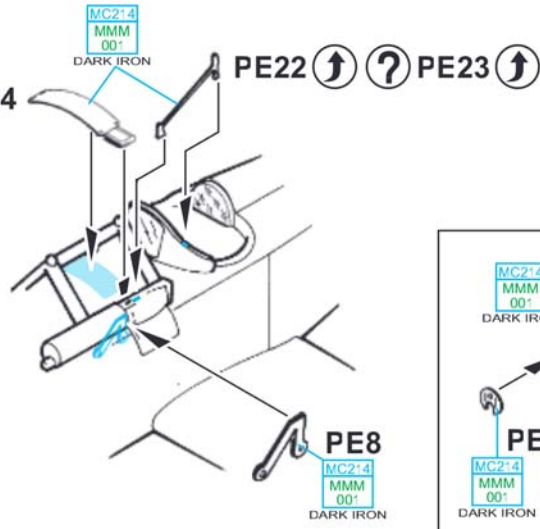
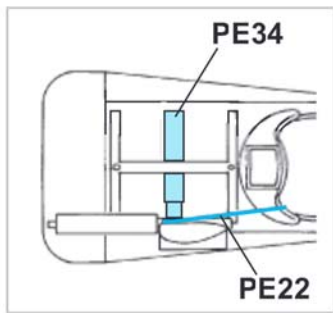
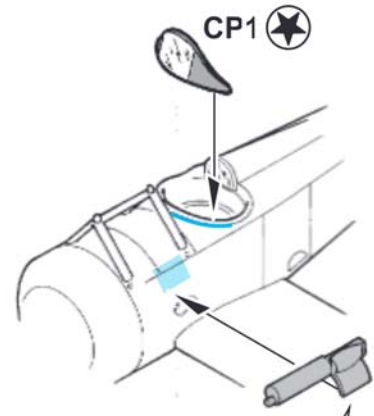
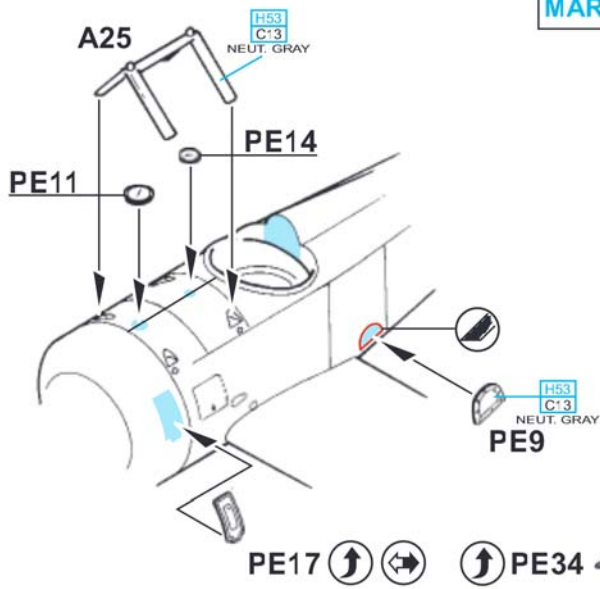

?

MARKING E

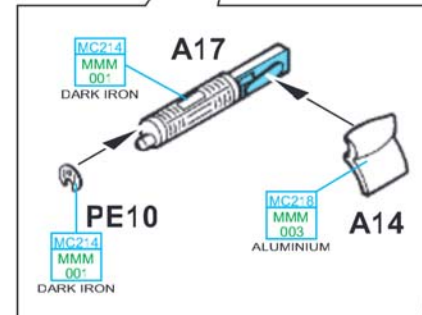
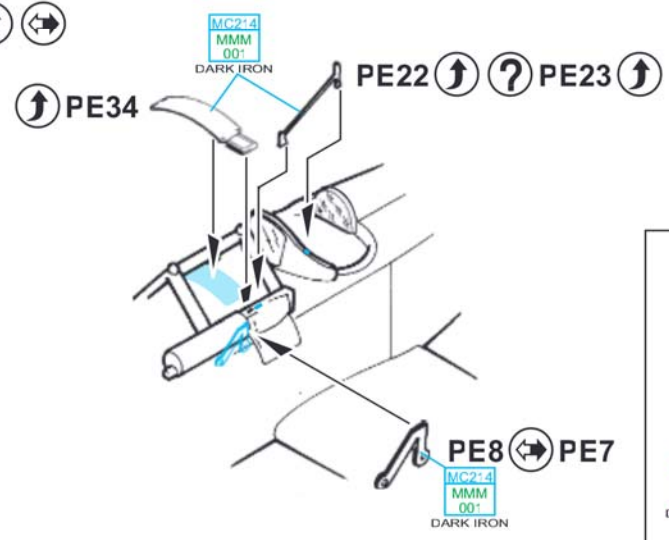
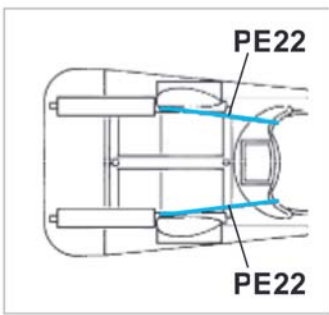
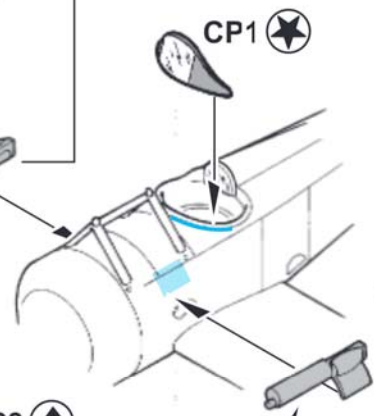
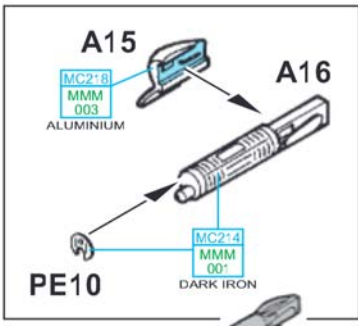
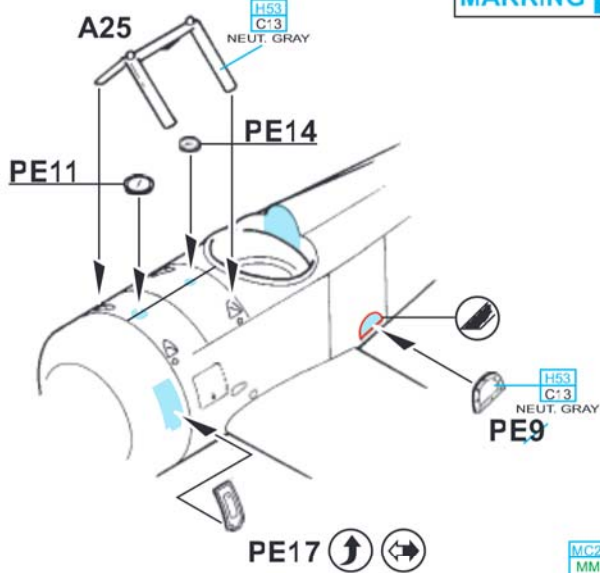

MARKINGS B, D, F

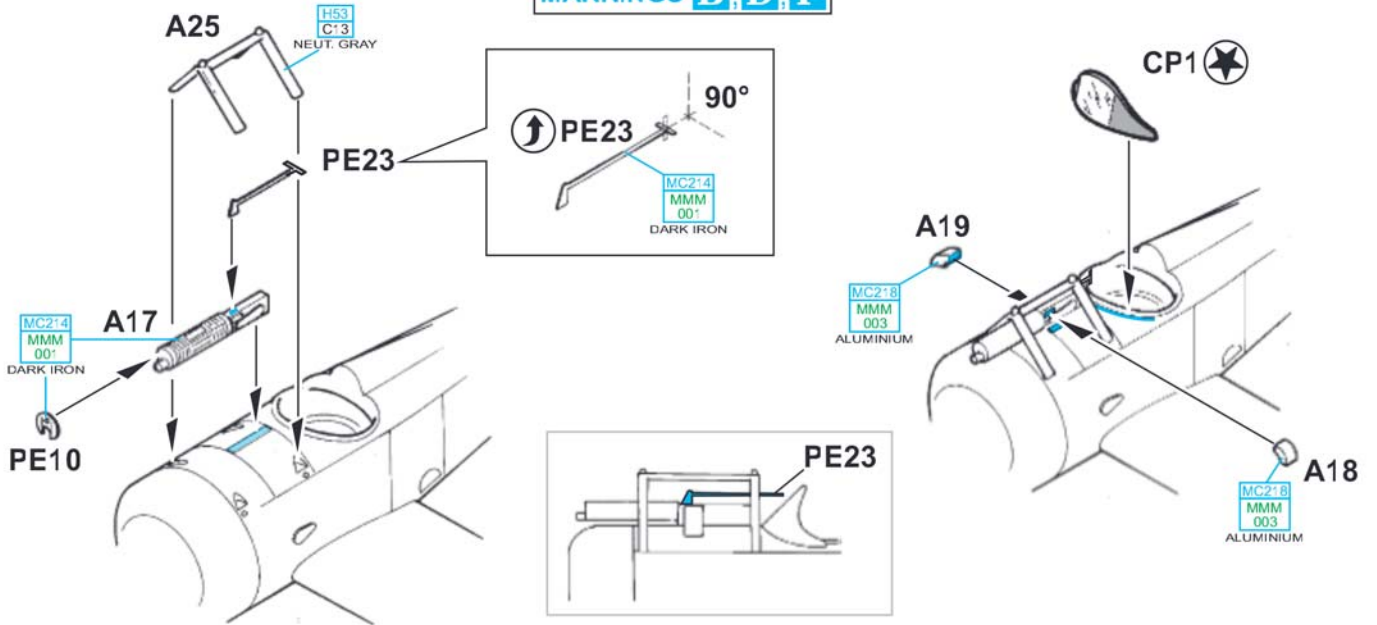

MARKING C ONLY

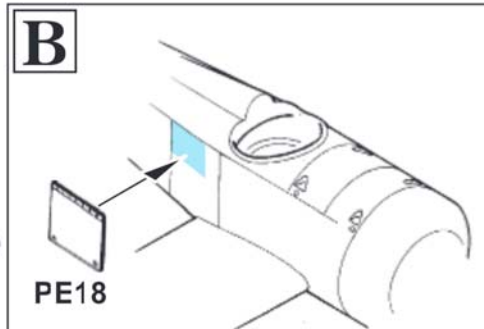
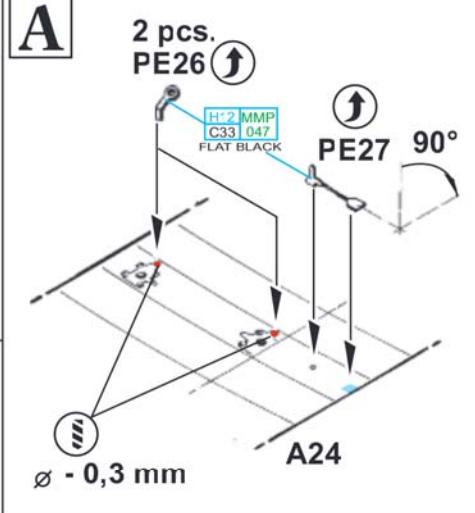
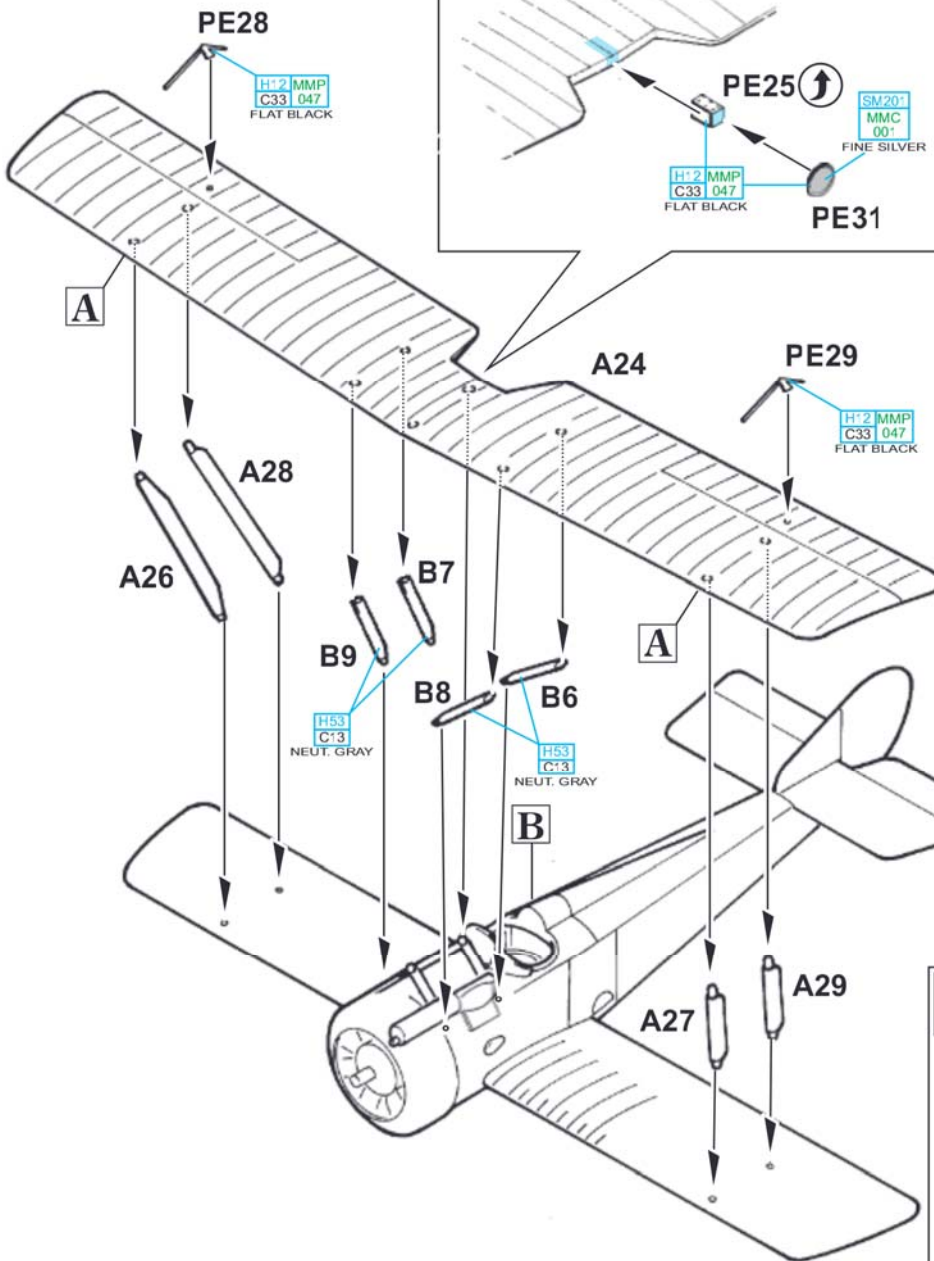

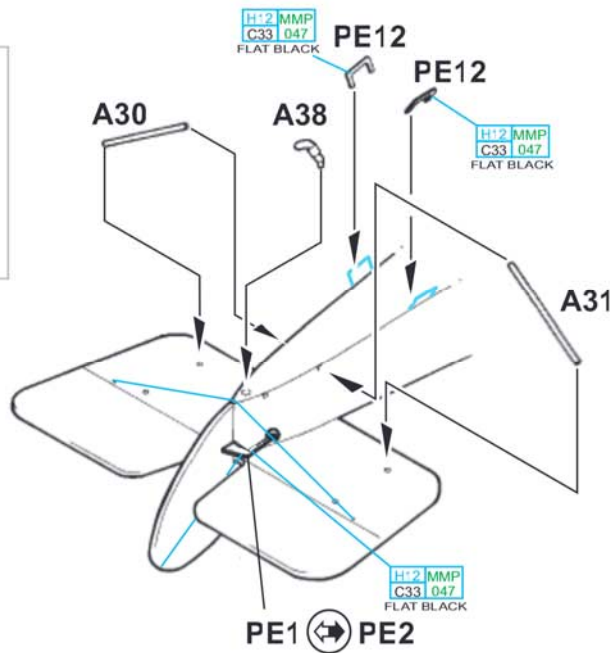
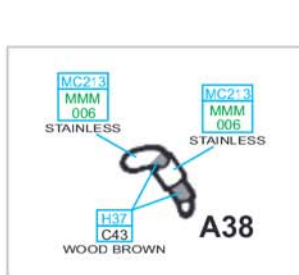
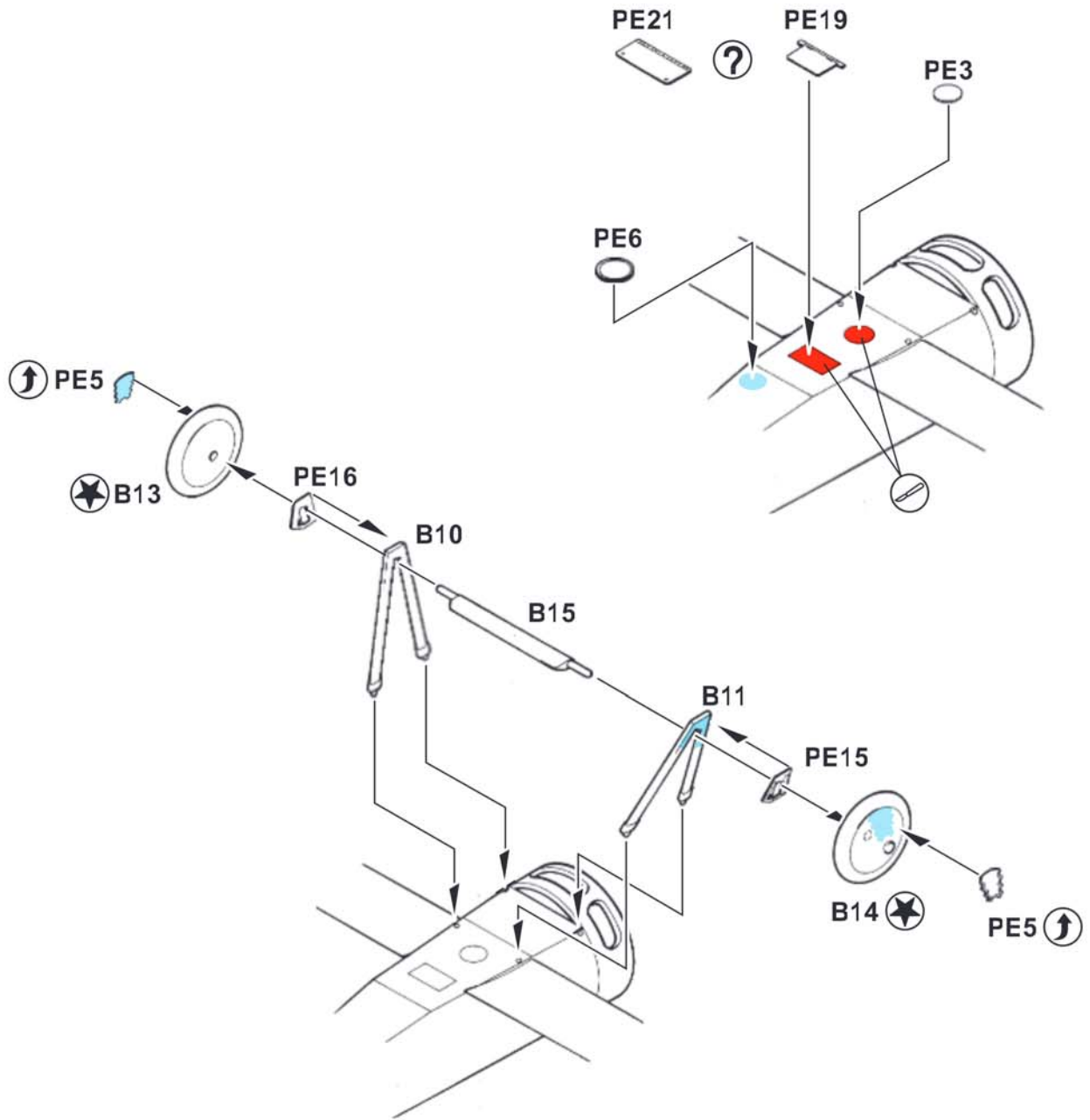

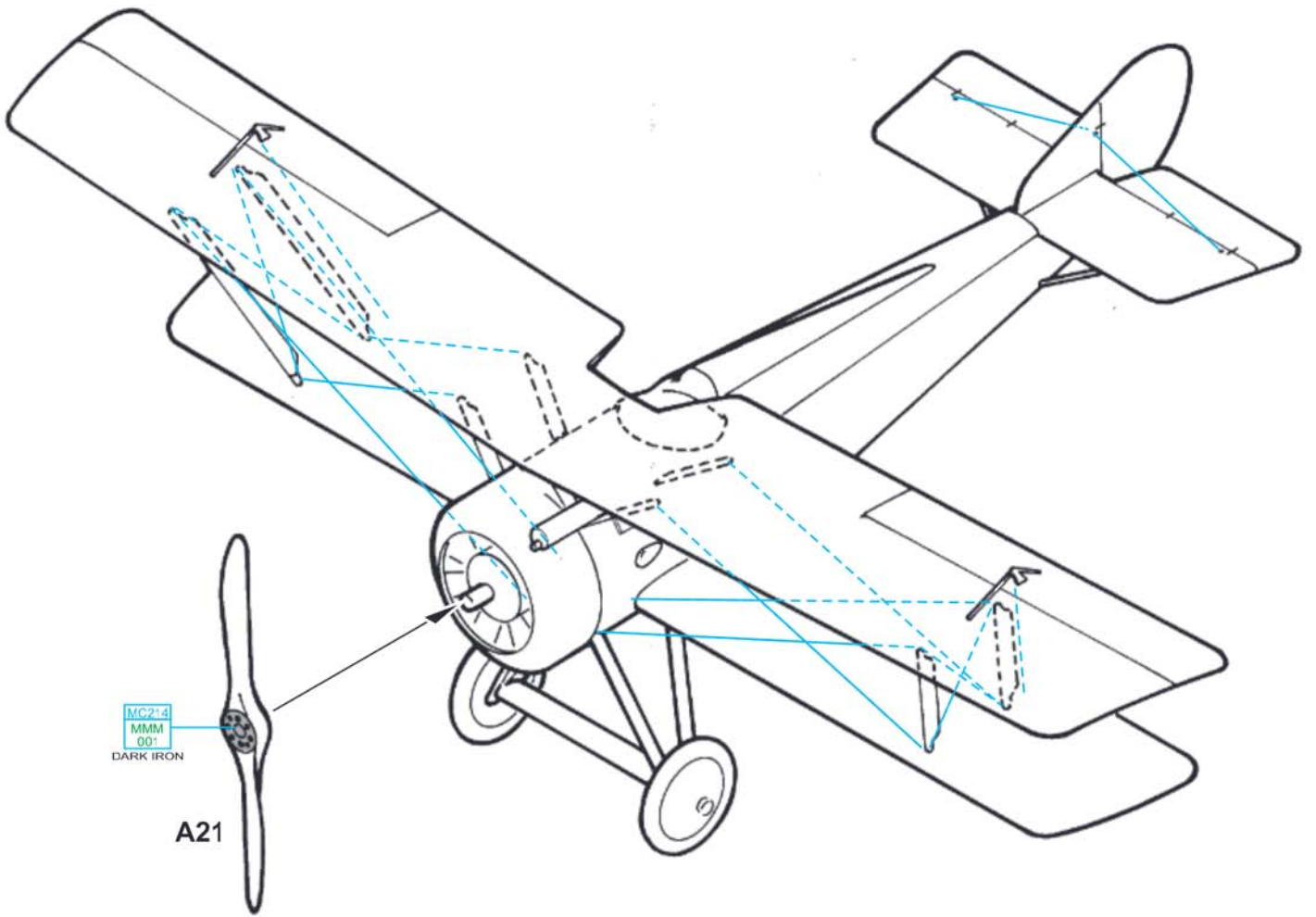
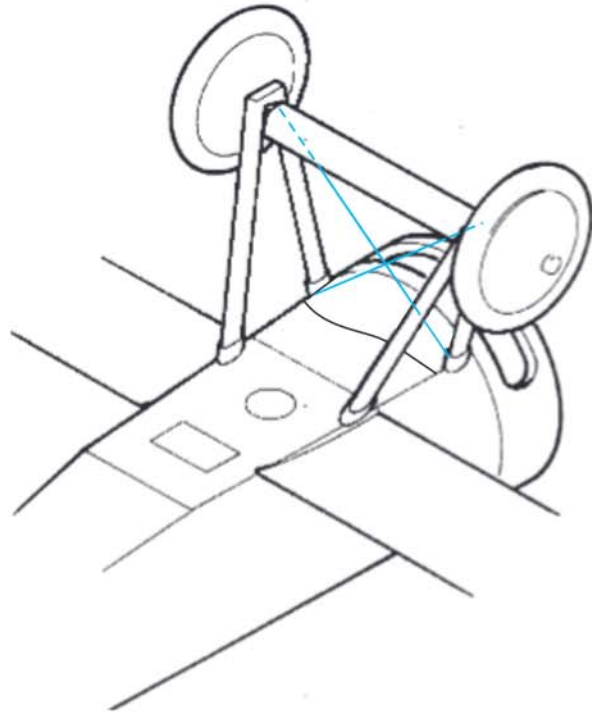

eduard
MASK

11139

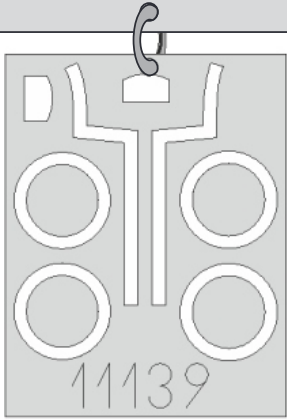

LIQUID MASK

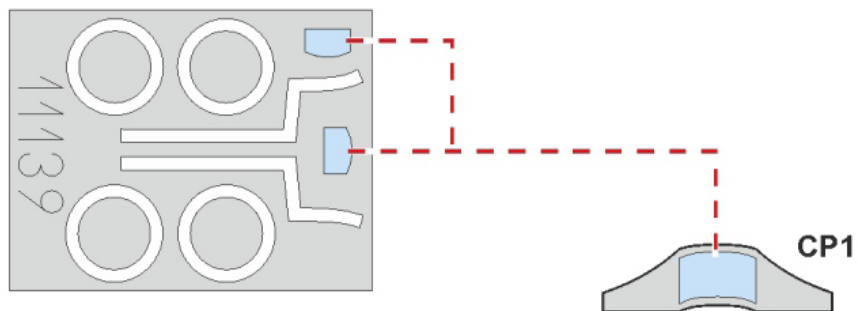
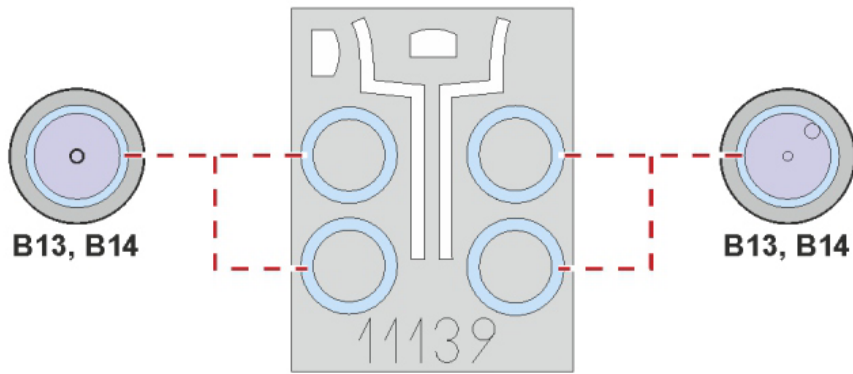
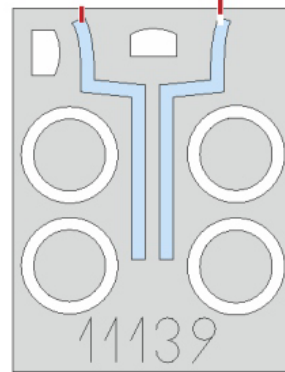
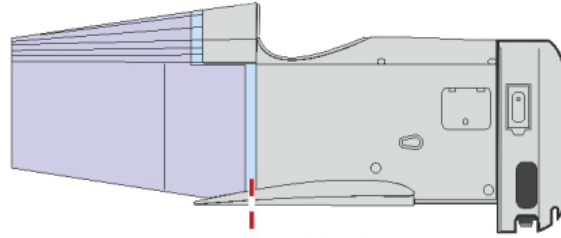

B No. 6254, flown by Sottotenente Giorgio Michetti, 76a Squadriglia, Casoni, Italy, 1918

Giorgio Michetti was called to active duty in the army in 1915, where he was assigned to the 27th Field Artillery Regiment, but by his own request, he was transferred to the air force. After the required training, he was assigned to a reconnaissance unit. On June 20th, he began his fighter training and on July 29th, 1917, his career as a fighter pilot began with 76a Squadriglia, during the course of which he registered five kills. He is also known for a practical joke he played, in which he flew over the trenches of Austro-Hungarian infantry with a bag full of rats, depositing his cargo over his target. Giorgio Michetti died on February 4th, 1966 in Rome. The Hanriots flown by 76a Squadriglia were likely the most decorated in the Italian Air Force. Giorgio Michetti had a sea horse in a white ring painted on the sides of his aircraft and on the stabilisers.

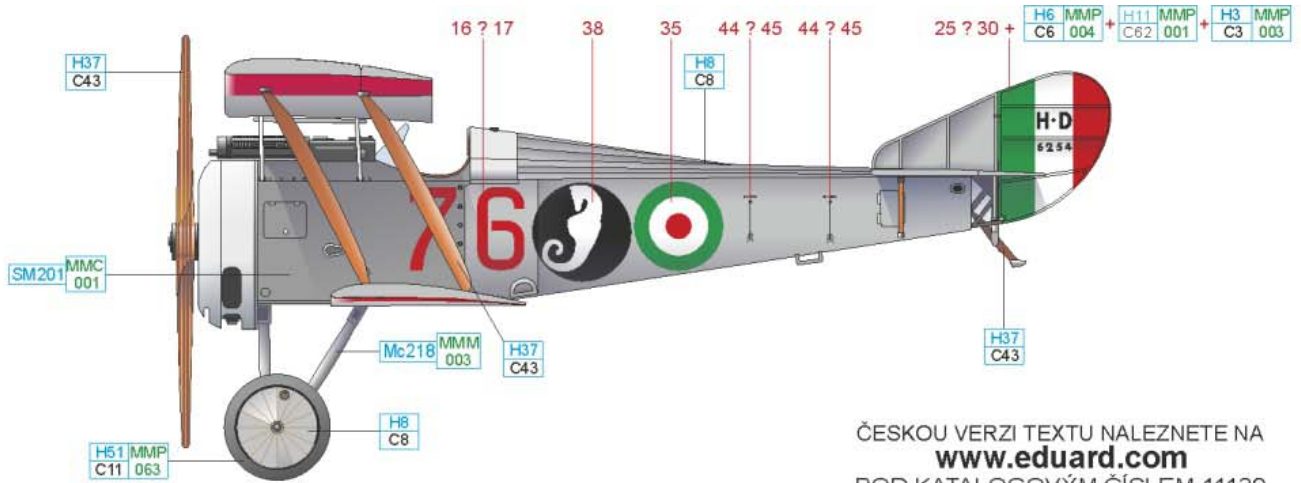

ČESKOU VERZI TEXTU NALEZNETE NA www.eduard.com
POD KATALOGOVÝM ČÍSLEM 11139

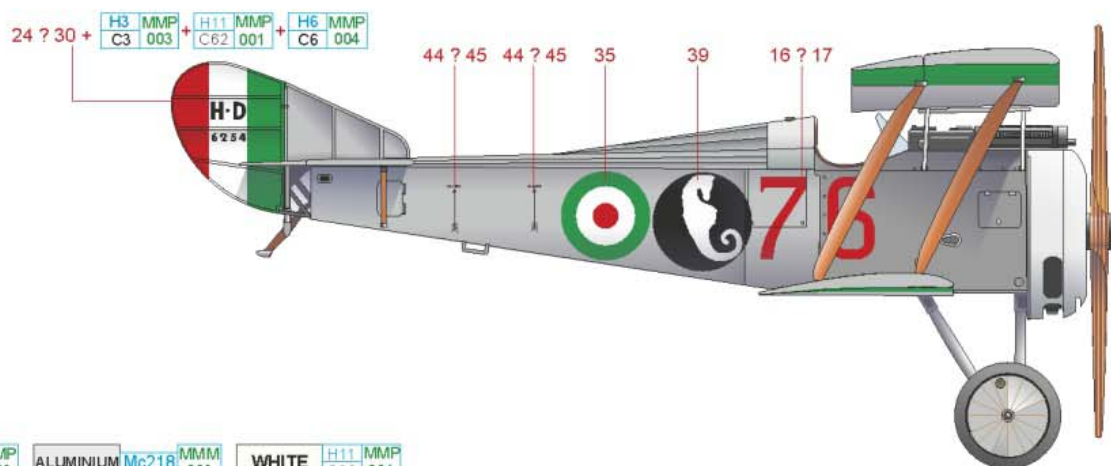
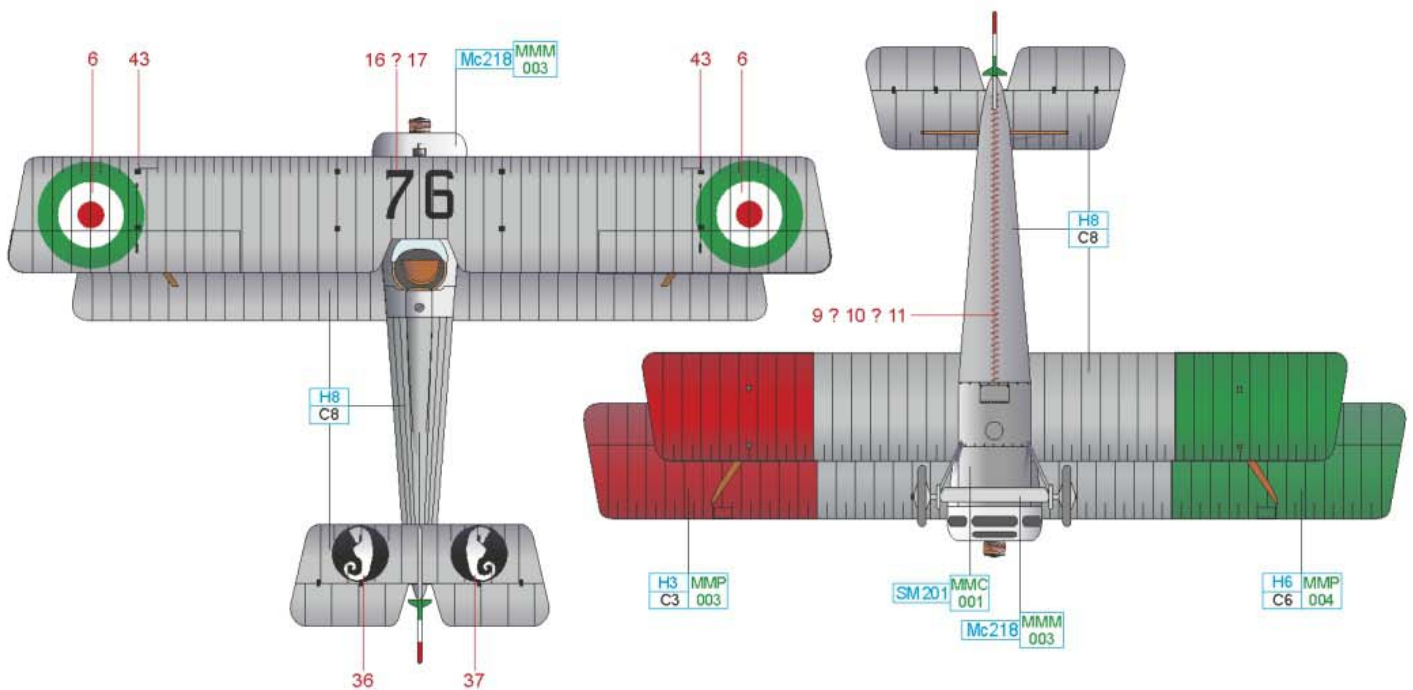

LIGHT GULL GRAY	H51 MMP C11 063	ALUMINIUM	Mc218 MMM 003	WHITE	H11 MMP C62 001
SUPER FINE SILVER	SM201 MMC 001	SILVER	H8 C8	WOOD	H37 C43
				RED	H3 MMP C3 003
				GREEN	H6 MMP C6 004

C 85a Squadriglia, Albania, late 1918

The 85a Squadriglia was formed on September 25th, 1917 and fought up to the end of the First World War on the Albanian front. The first equipment of the unit was composed of French Nieuport fighters, which were replaced the following year by Hanriot HD.Is. The unit was disbanded in October 1919. As with the pilots of other nationalities, the Italians had a tendency to decorate their aircraft. A rendition of playing cards was not limited to aircraft of the 85a Squadriglia, but have also been seen on aircraft of Tenente Baracchini of the 76a Squadriglia.

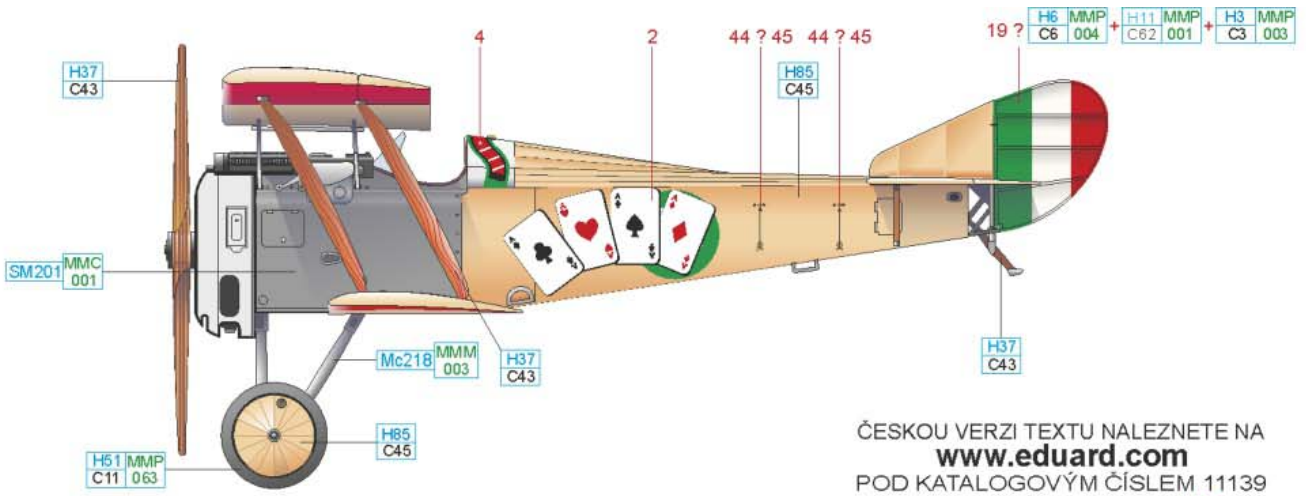

ČESKOU VERZI TEXTU NALEZNETE NA www.eduard.com
POD KATALOGOVÝM ČÍSLEM 11139

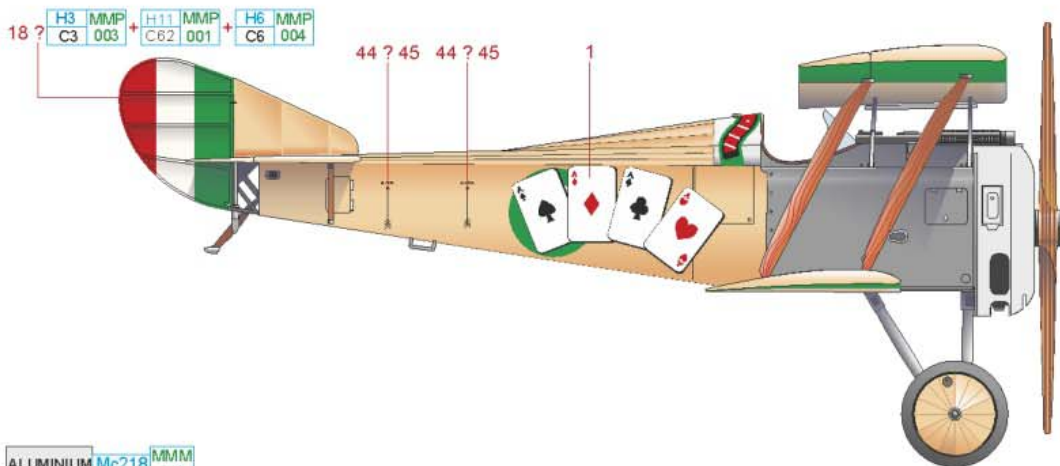
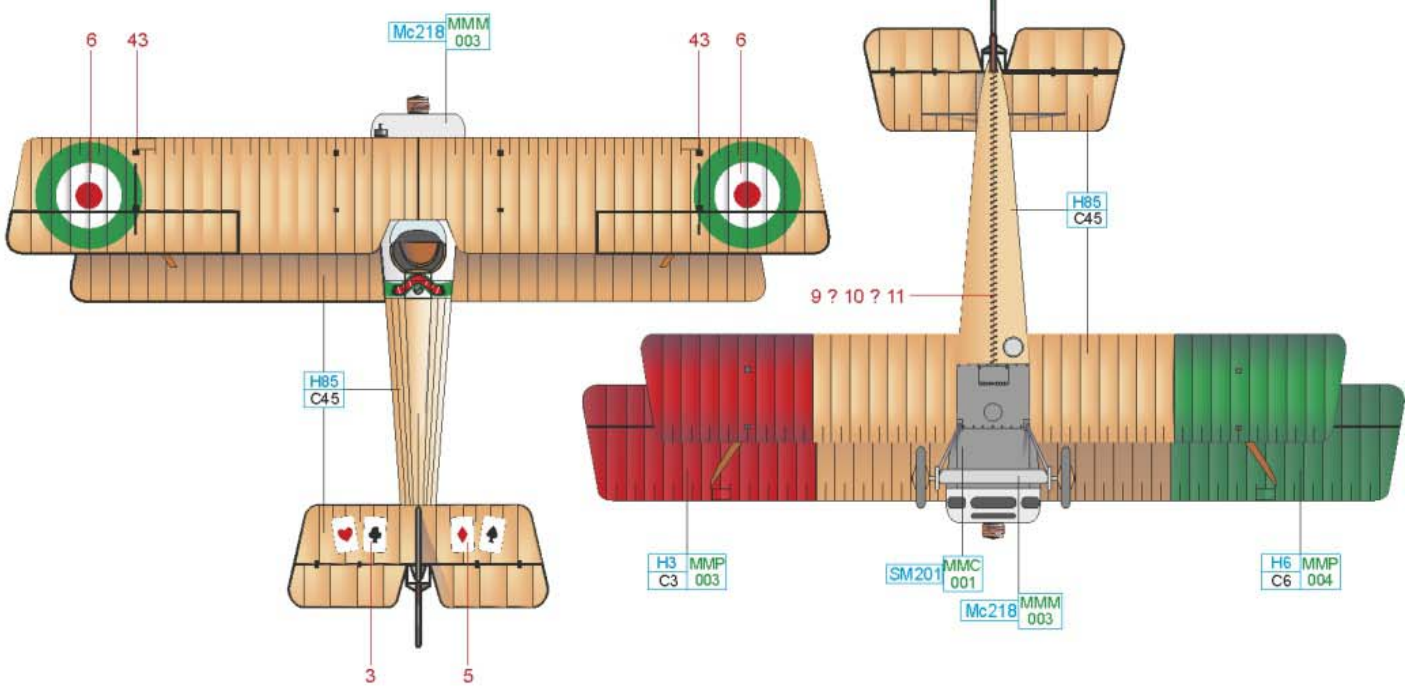

LIGHT GULL GRAY	H51 MMP C11 063	ALUMINIUM	Mc218 MMM 003
SUPER FINE SILVER	SM201 MMC 001	SAIL COLOR	H85 C45
WOOD	H37 C43	RED	H3 MMP C3 003
GREEN	H6 MMP C6 004		

D No. 562, flown by Tenente Antonio Bogliolo, 81a Squadriglia, Italy, 1918

81a Squadriglia was formed in March 1917, and in April reached its base Arcade, near Venice, armed with the Nieuport 11. Over the course of the year, the Nieuport 17 also appeared, and these were replaced in February 1918 by the Hanriot HD.1. Their number was unsatisfactory, and so they were supplemented by Nieuport 27s. These aircraft would serve out the remainder of the war, flying 4,118 combat flights and accounting for 34 kills. The aircraft flown by Tenente Boglioli was adorned with stars on the fuselage side and the fin, and the number of the unit appeared below the cockpit, which was also repeated on the upper wing.

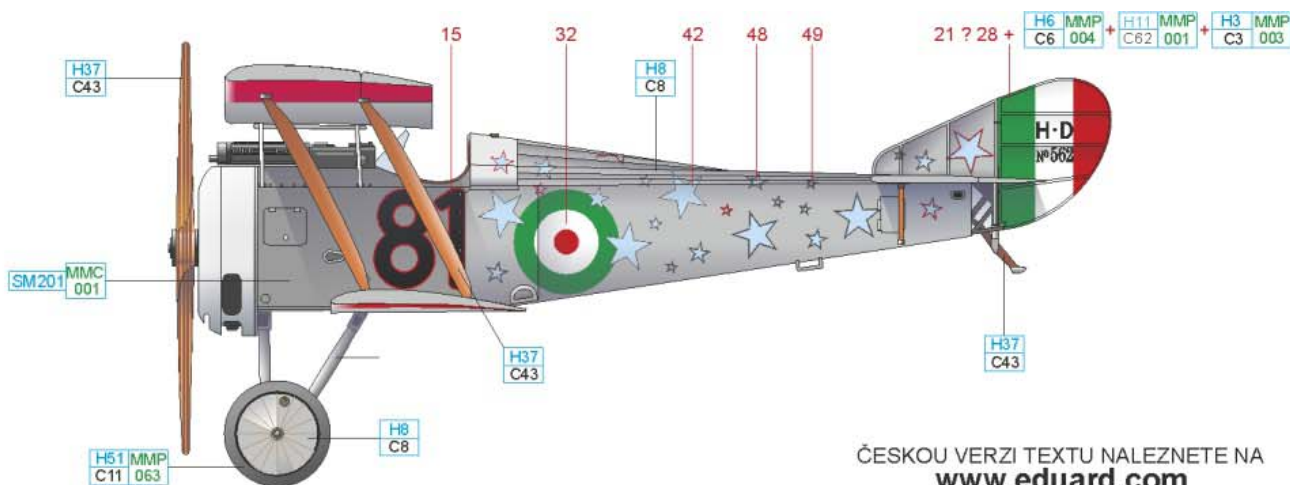

ČESKOU VERZI TEXTU NALEZNETE NA
www.eduard.com
POD KATALOGOVÝM ČÍSLEM 11139

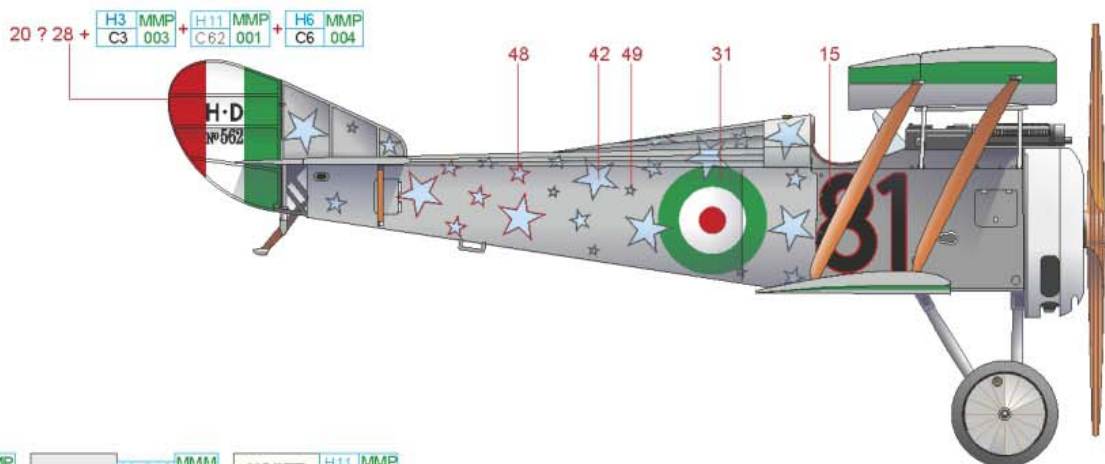
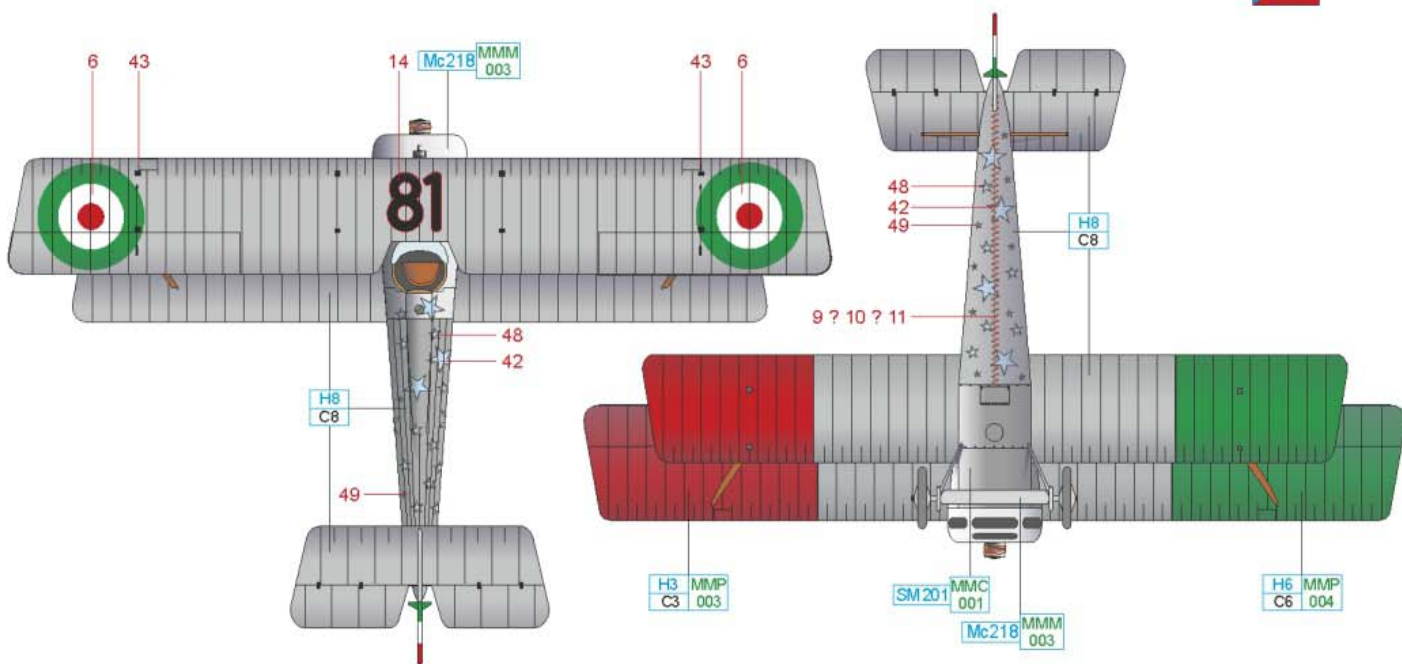

LIGHT GULL GRAY	H51 MMP C11 063	ALUMINIUM	Mc218 MMM 003	WHITE	H11 MMP C62 001
SUPER FINE SILVER	SM201 MMC 001	SILVER	H8 C8	WOOD	H37 C43
				RED	H3 C3 003
				GREEN	H6 MMP C6 004

E flown by Tenente Mario Fucini, 78a Squadriglia, Italy, Autumn 1918

Mario Fucini entered the Italian Air Force in 1915, when he was assigned to 25a Squadriglia, flying Voisin aircraft. In the spring of 1917, he requested a transfer to a fighter unit, and after undergoing the necessary training, he joined 76a Squadriglia, with which he would gain his first kill on November 13th, 1917. On February 11th the following year, he was transferred to the 78a Squadriglia, and he would remain there until the end of the First World War, accumulating seventeen kills in the process. After the war, he remained with the air force, until being discharged in 1937. He would later write a book about his experiences during the war years. He died on September 1st, 1977 in Rome. Tenente Fucini commemorated his kills in the form of black skulls on a white flag, painted on his Hanriot. The number of the Squadriglia was painted below the cockpit of the aircraft.

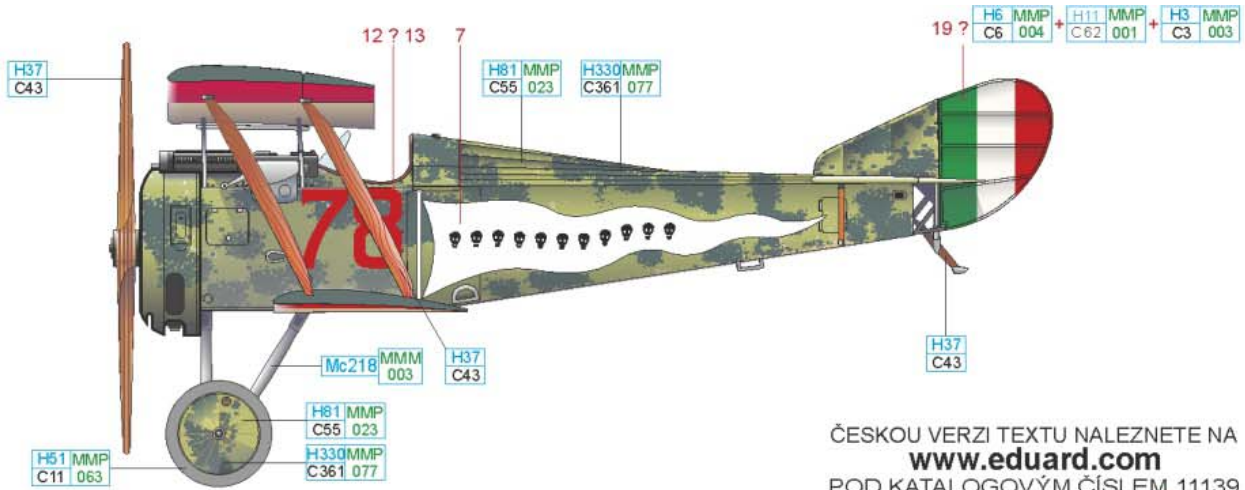

ČESKOU VERZI TEXTU NALEZNETE NA
www.eduard.com
POD KATALOGOVÝM ČÍSLEM 11139

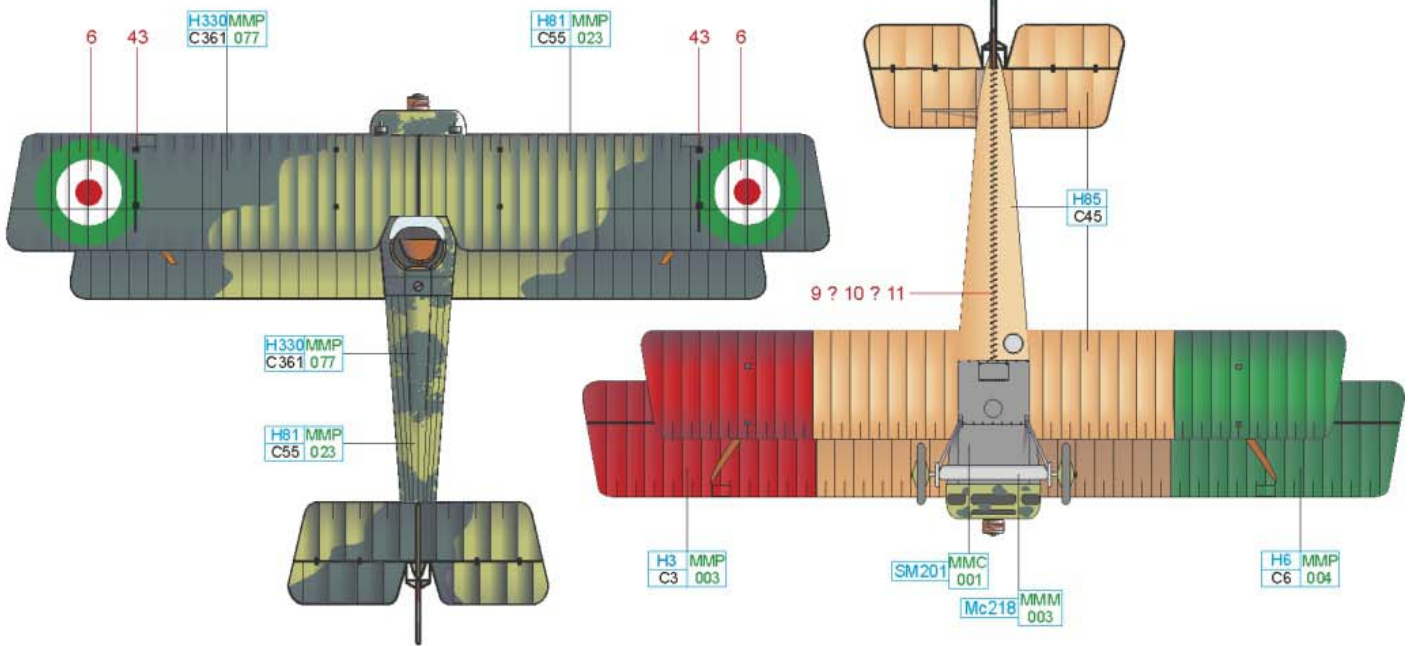

LIGHT GULL GRAY	H51 MMP C11 063	ALUMINIUM	Mc218 MMM 003	KHAKI	H81 MMP C55 023	DARK GREEN	H330MMP C361 077
SUPER FINE SILVER	SM201 MMC 001	SAIL COLOR	H85 C45	WOOD	H37 C43	RED	H3 MMP C3 003
						GREEN	H6 MMP C6 004

F No. 11432, 80a Squadriglia, Italy, 1918

As was the case with her sister unit 81a Squadriglia, this unit was also formed at Arcade, near Venice. In March 1917, the unit received the Nieuport 11. Conversion to the Hanriot HD.I came in the spring of 1918, and with these aircraft, the unit would fight to the end of the First World War. Over the course of this time, the unit's pilots flew 4,637 combat flights and amassed 21 kills without a single loss of life to itself. Hanriots of 80a Squadriglia had the Lion of St. Mark painted on their sides. The majority of Italian Hanriots did not carry the national insignia on the lower wings, but did have green (right) and red (left) wingtips.

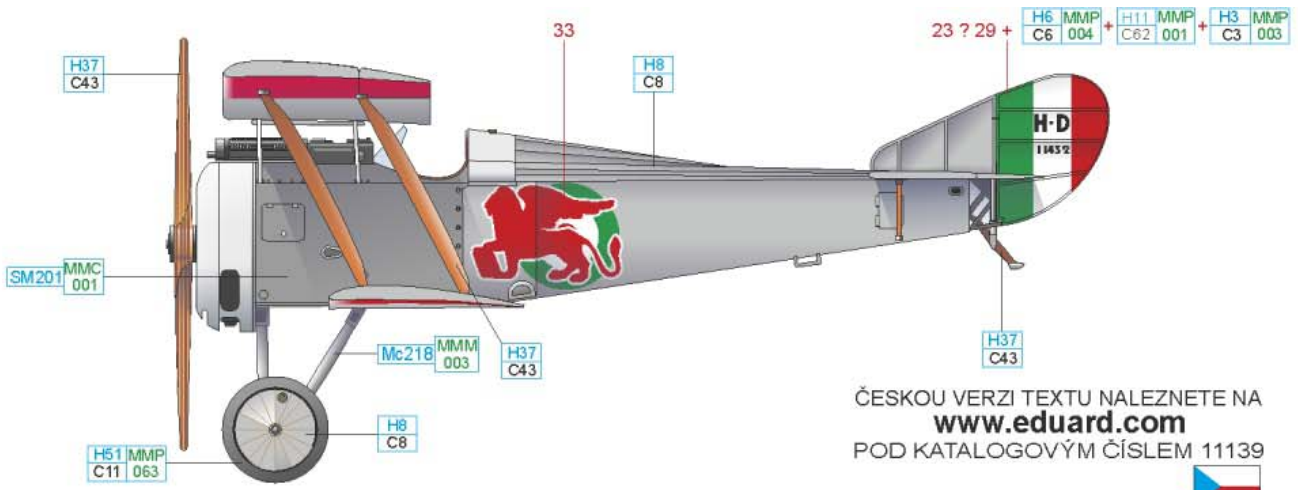

ČESKOU VERZI TEXTU NALEZNETE NA
www.eduard.com
POD KATALOGOVÝM ČÍSLEM 11139

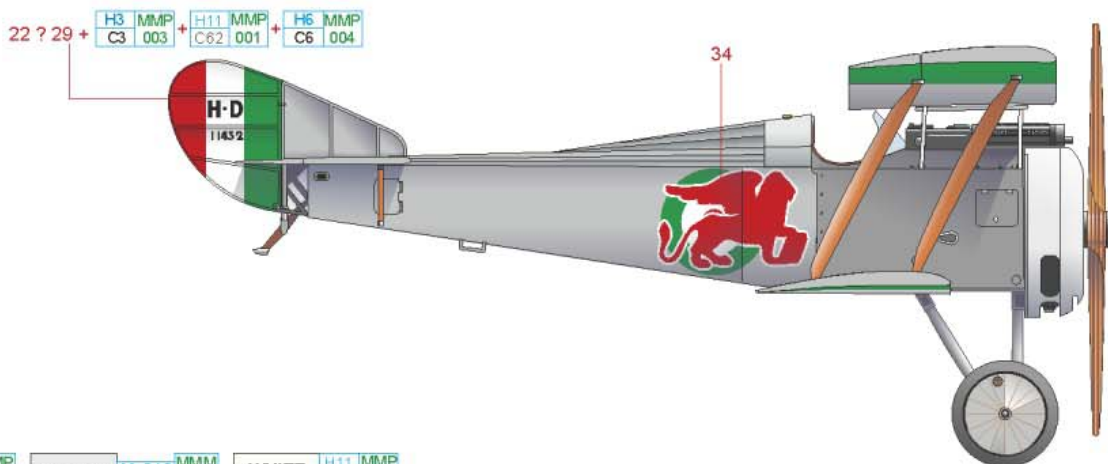
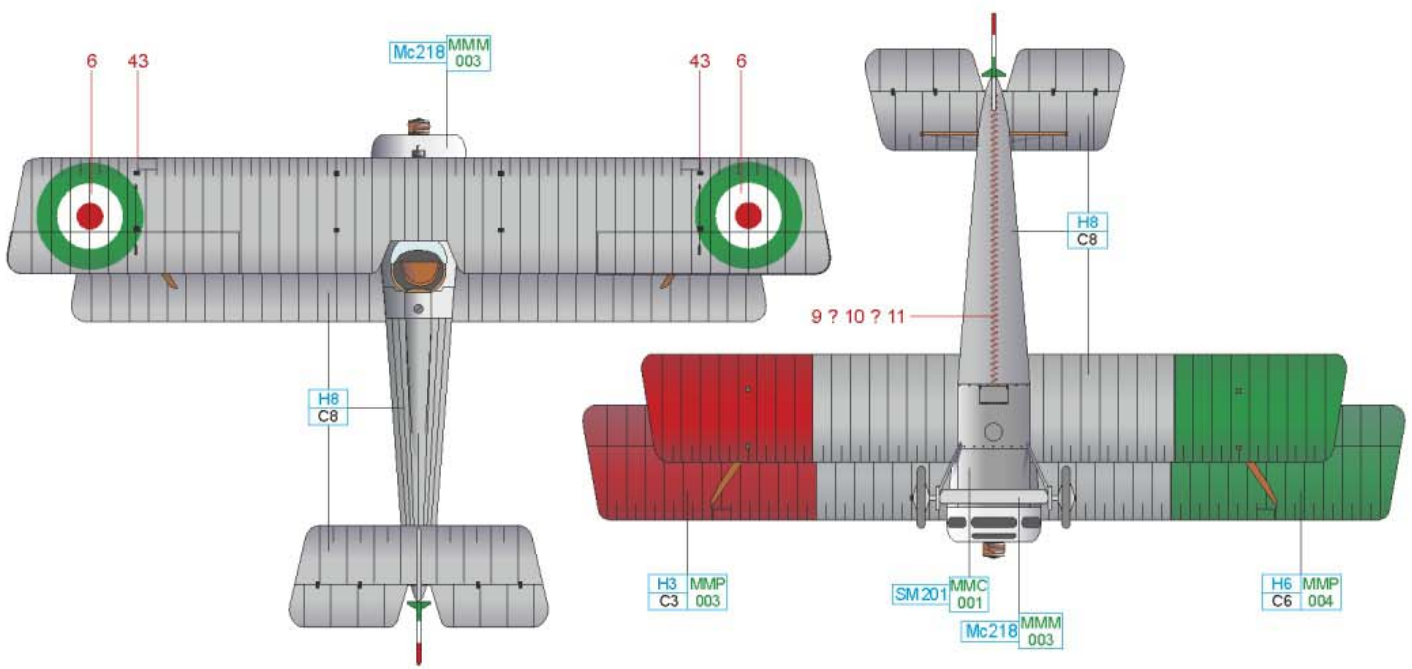

LIGHT GULL GRAY	H51 MMP C11 063	ALUMINIUM	Mc218 MMM 003	WHITE	H11 MMP C62 001
SUPER FINE SILVER	SM201 MMC 001	SILVER	H8 C8	WOOD	H37 C43
				RED	H3 C3 003
				GREEN	H6 C6 004

Nieuport Ni-17

1/48

eduard



N1530, Lt. Georges Guynemer, Escadrille N 3, Cachy, France, August 1916



N3139, Ten. Fulco Ruffo di Calabria, 91a squadriglia, Italian front, spring 1917



N1427, Adj. Paul Tarascon, Escadrille N 62, Cachy, France, July 1916



N1844, Cne. Raoul Lufbery, Lafayette Escadrille, Cachy, France, late 1917



N1571, S/Lt. Charles Nungesser, Escadrille N 65, Cachy, France, summer 1916



ProfiPACK
edition

Cat. No. 8071 www.eduard.com